

MODEL QUESTION PAPER – 1

For 2020-21 Only

I PUC ELECTRONICS [40]

Time: 3 Hour 15 minute

Max Marks: 70

Instructions:

1. The question paper has four parts: A, B, C and D.
2. Part – A is compulsory.
3. Part – D contains two sub parts (I) Numerical problems
(II) Essay type questions.
4. Read the instructions given for each part.

PART–A

Answer ALL questions.

10 × 1 = 10

1. What is electronics?
2. What is a node?
3. How do you arrange cells to get desired current rating?
4. What is the SI unit of capacitance?
5. Name the majority charge carriers in n–type semiconductor.
6. What is meant by depletion region?
7. Draw the equivalent circuit of a forward biased ideal diode.
8. What is a AND gate?
9. How is 1's complement of a binary number obtained?
10. Convert 1001_2 into decimal number.

PART–B

Answer any FIVE questions.

5 × 2 = 10

11. Silicon is more preferred than germanium in semi conductor devices fabrication, justify.
12. State Super position theorem.
13. Compare ideal and practical voltage sources.
14. How much energy is stored in a 20 μF capacitor with a voltage rating of 15 volts?
15. A p–n junction diode is a non linear element. Explain.
16. Distinguish between the digital and analog signals.
17. Construct logic circuit for the Boolean expression $Y = AB + BC$.
18. Prove that $A + \overline{AB} = A + B$

PART–C

Answer any FIVE questions

5 × 3 = 15

19. Mention any three properties of charges.
20. Define the terms mesh, branch and loop in an electrical network.
21. Draw any three non sinusoidal waveforms.
22. Write a note on power rating of a resistor.
23. Mention any three applications of a relay.
24. Write a note on formation of p–type semiconductor.

25. Calculate the load voltage and load current for the circuit shown.

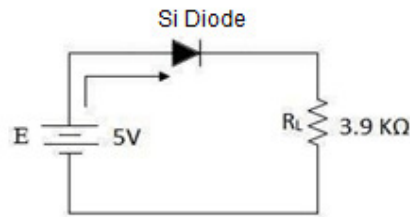

26. Mention three widely used number systems.

PART-D

I Answer any THREE questions.

3 × 5 = 15

27. Determine the branch currents in the given figure.

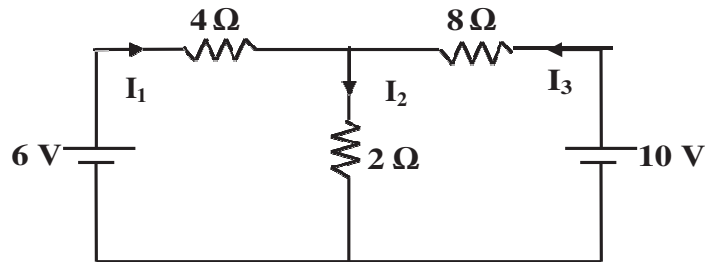

28. Using Thevenin's theorem, find the load current and load voltage for the following circuit.

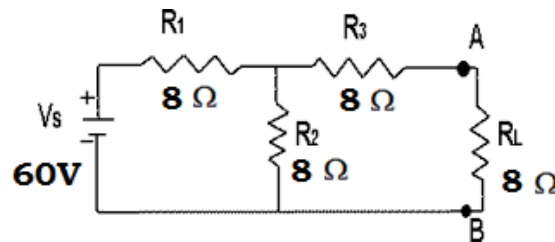

29. Two capacitors of capacitance $10 \mu\text{F}$ and $30 \mu\text{F}$ are connected in series across 100 V dc supply. Determine a) effective capacitance b) the total charge on combination c) potential difference across each capacitor.
30. Subtract 1111_2 from 11001_2 using 2's complement method. Also verify the same by direct subtraction method.
31. Simplify the Boolean expressions:
 a) $Y = (\bar{A} + \bar{C})(\bar{B} + C)(\bar{A} + B)$
 b) $Y = (A + \bar{B}C)(A\bar{B} + C)$

II Answer any FOUR questions.

4 × 5 = 20

32. Derive an expression for the effective resistance of two resistors connected in parallel.
33. Explain the constructional feature of a carbon film resistor.
34. Explain principle of a capacitor.
35. Draw and explain the V-I characteristics of a p-n junction diode.
36. Explain the operation of bridge rectifier.
37. Explain two input NAND gate.
-

MODEL QUESTION PAPER - 2
For 2020 – 21 ONLY
I PUC ELECTRONICS [40]

TIME : 3hr. 15min

MAX. MARKS : 70

Instructions:

1. The question paper has four parts: A, B, C and D
2. Part - A is compulsory.
3. Part - D contains two sub parts (I) Numerical problems
(II) Essay type questions.
4. Read the instructions given for each part.

PART – A

I. Answer ALL questions:

10 X 1 = 10

1. Expand WAN.
2. Write the symbol of AC source.
3. What is electric current?
4. Name any one variable resistor.
5. Name the majority charge carriers in p-type semiconductor.
6. What is a hole?
7. Define static forward resistance of a diode.
8. Write the circuit symbol of a two input NAND gate.
9. Convert the given hexadecimal number $AB3_{16}$ to binary number.
10. Prove that $A+AB = A$.

PART - B

II. Answer any FIVE of the following questions:

5 X 2 = 10

11. Mention any two applications of electronics.
12. Mention limitations of Ohm's law.
13. Draw the V-I characteristics of a practical voltage source.
14. Determine the charge on $30 \mu\text{F}$ capacitor charged to 20 volt.
15. Distinguish between Ge and Si diode.
16. What is the difference between bit and a byte?
17. Write the truth table of two input NOR-gate.
18. What is positive logic and negative logic?

PART – C

III. Answer any FIVE of the following questions:

5 X 3 = 15

19. What are primary and secondary batteries? Give an example for each.
 20. Define the terms time period, frequency and peak voltage relating to AC waveform.
 21. Explain voltage divider rule.
-

22. Write a note on iron core inductors.
23. Discuss importance of voltage rating of capacitors.
24. Write a note on the formation of n-type semiconductor.
25. For the series diode configuration shown in the figure, determine the I_D and V_R

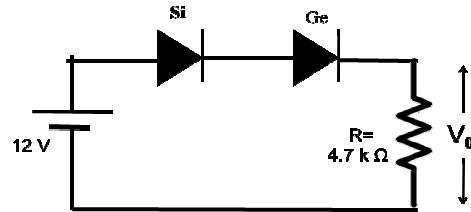

26. Write the circuit diagram and truth table of two input diode OR gate.

PART – D

I. Answer any THREE questions:

3 X 5=15

27. Find the total resistance between the points A and B, draw the equivalent circuit and hence find (i) the current I in the circuit (ii) total power dissipated in the circuit .

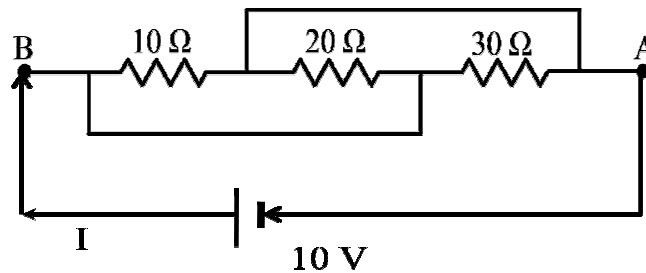

28. Using Thevenin's theorem, find the voltage and current through load resistance R_L of the following circuit.

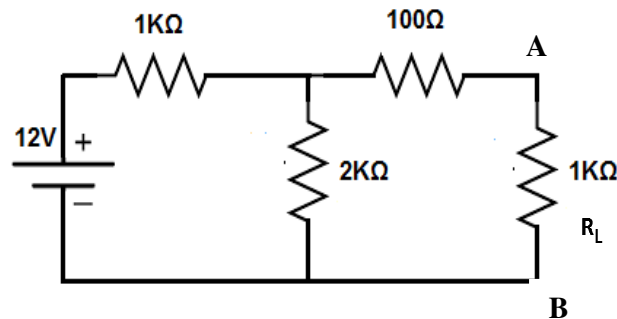

29. Two capacitors of $10 \mu\text{F}$ each are connected in parallel. The combination is further connected in series with two capacitors of $2 \mu\text{F}$ and $5 \mu\text{F}$. Calculate the total capacitance of the circuit.
30. Subtract the number $(85)_{10}$ from $(113)_{10}$ using 2's complement method.
31. Simplify the Boolean expression $Y = \bar{A}B\bar{C} + \overline{ABC} + A\bar{B}\bar{C} + \bar{A}\bar{B}\bar{C}$ and draw the logic circuit for the simplified expression using basic gates.

II. Answer any FOUR questions:

4 X 5=20

32. Distinguish between DC and AC current.
 33. Explain the constructional features of an electrolytic capacitor and mention its applications.
 34. Explain the specifications of resistor.
 35. Classify solids on the basis of energy band diagram.
 36. Explain the working of center tapped full wave rectifier.
 37. State and prove De-Morgan's theorem.
-
-